

D2n Relay V23105

- Standard DIL relay
- Dimensions 20x10x11mm (.795x.394x.433")
- Switching and continuous current 3A
- 2 form C contacts (2 CO, 2 changeover contacts)
- Immersion cleanable
- Four different coil sensitivities, 150mW, 200mW, 400mW, >500mW
- Surge voltage resistance meets FCC Part 68 requirement: 1.5kV (10/700µs) between coil and contacts

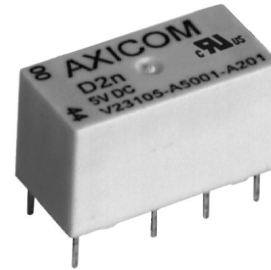

Typical applications

Communications equipment, office equipment, measurement and control equipment, entertainment electronics, medical equipment, consumer electronics

Approvals

UL 508 File No. E 111441
Technical data of approved types on request

Contact Data

| | |
|-------------------------------------|------------------------------------|
| Contact arrangement | 2 form C (CO) |
| Max. switching voltage | 220VDC, 250VAC |
| Rated current | 3A |
| Limiting continuous current, 85°C | 3A |
| Contact material | AgNi, gold-covered |
| Min. recommended contact load | 10mA at 20mV |
| Minimum switching voltage | 100µV |
| Initial contact resistance | <100mΩ at 10mA, 20mV |
| Frequency of operation without load | max. 50 operations/s |
| Operate / release time max. | 6ms/4ms |
| Bounce time max. | 5 ms |
| Electrical endurance | |
| at 230VAC/0.5A | typ. 3x10 ⁵ operations |
| at 6VDC/0.1A | typ. 2x10 ⁶ operations |
| at 30VDC/1A | typ. 5x10 ⁵ operations |
| at 30VDC/2A | typ. 1x10 ⁵ operations |
| Contact ratings, UL | 30VDC/1.0A |
| | 100VDC/0.3A |
| 150mW and 200mW coil | 125VAC/0.5A |
| 400mW and 500mW coil | 125VAC/1.0A |
| Mechanical endurance | typ. 15x10 ⁶ operations |

Coil Data

| | |
|-----------------------|------------|
| Magnetic system | neutral |
| Coil voltage range | 3 to 48VDC |
| Max. coil temperature | 85 °C |
| Thermal resistance | < 85K/W |

Coil versions, monostable

| Coil code | Rated voltage VDC | Operate voltage VDC | Limiting Voltage VDC | Release voltage VDC | Coil resistance Ω±10% | Rated coil power mW |
|-----------------------------|-------------------|---------------------|----------------------|---------------------|-----------------------|---------------------|
| 150mW coil power | | | | | | |
| 001 | 5 | 4.0 | 11.7 | 0.25 | 167 | 150 |
| 002 | 6 | 4.8 | 14.0 | 0.30 | 240 | 150 |
| 006 | 9 | 7.2 | 21.0 | 0.45 | 540 | 150 |
| 003 | 12 | 9.6 | 28.0 | 0.60 | 960 | 150 |
| 005 | 24 | 19.2 | 56.0 | 1.20 | 3840 | 150 |
| 200mW coil power | | | | | | |
| 308 | 3 | 2.1 | 6.1 | 0.15 | 45 | 200 |
| 301 | 5 | 3.5 | 10.1 | 0.25 | 125 | 200 |
| 302 | 6 | 4.2 | 12.2 | 0.30 | 180 | 200 |
| 306 | 9 | 6.3 | 18.2 | 0.45 | 405 | 200 |
| 303 | 12 | 8.4 | 24.3 | 0.60 | 720 | 200 |
| 305 | 24 | 16.8 | 48.6 | 1.20 | 2880 | 200 |
| 307 | 48 | 33.6 | 97.2 | 2.40 | 11520 | 200 |
| 400mW coil power | | | | | | |
| 401 | 5 | 3.5 | 7.2 | 0.25 | 62 | 400 |
| 402 | 6 | 4.2 | 8.6 | 0.30 | 90 | 400 |
| 406 | 9 | 6.3 | 12.9 | 0.42 | 203 | 400 |
| 403 | 12 | 8.4 | 17.2 | 0.60 | 360 | 400 |
| 405 | 24 | 16.8 | 34.3 | 1.20 | 1440 | 400 |
| 407 | 48 | 33.6 | 68.6 | 2.40 | 5760 | 400 |
| >500mW coil power | | | | | | |
| 501 | 5 | 3.5 | 6.1 | 0.25 | 36 | 695 |
| 502 | 6 | 4.2 | 7.3 | 0.30 | 70 | 515 |
| 506 | 9 | 6.3 | 10.9 | 0.45 | 140 | 580 |
| 503 | 12 | 8.4 | 14.5 | 0.60 | 280 | 515 |
| 505 | 24 | 16.8 | 29.1 | 1.20 | 1050 | 550 |
| 507 | 48 | 33.6 | 58.1 | 2.40 | 4000 | 575 |

All figures are given for coil without pre-energization, at ambient temperature +23°C. Other coil voltages on request.

Max. DC load breaking capacity

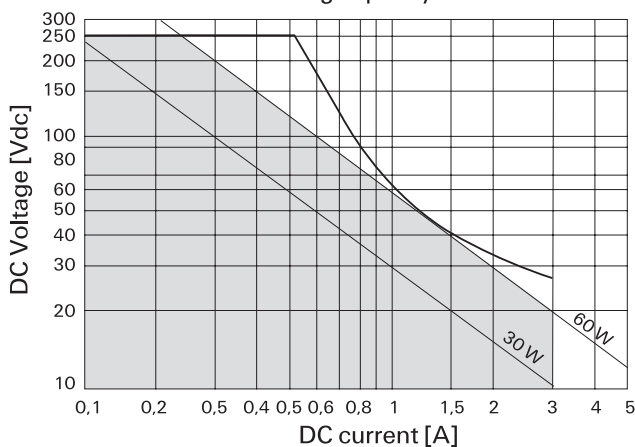

D2n Relay V23105 (Continued)

Coil Data (continued)

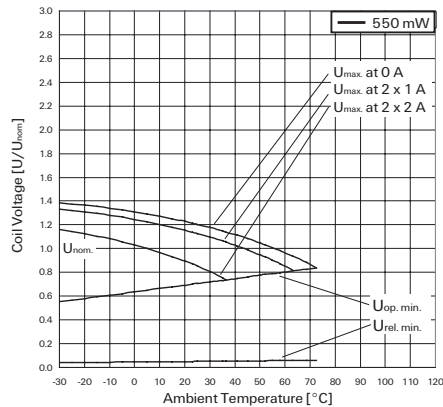
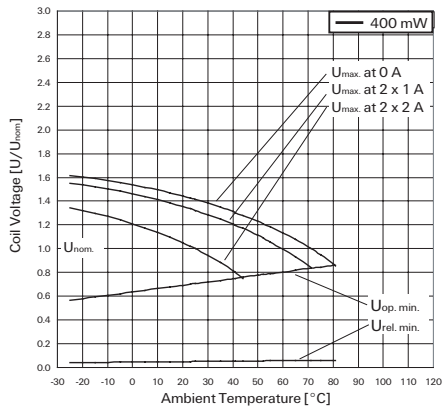
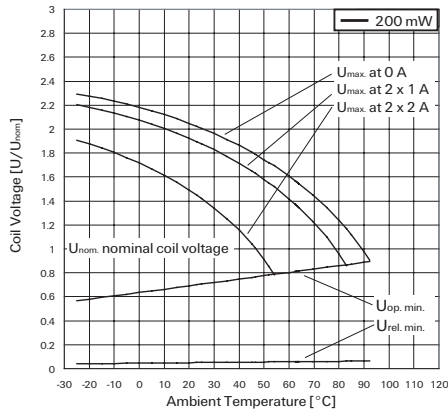
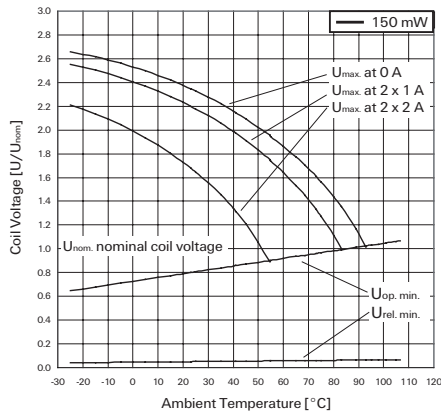

Coil Data (continued)

Coil operating range graphs

- U_{nom} Nominal coil voltage
- U_{max} Upper limit of the operative range of the coil voltage (limiting voltage) when coils are continuously energized
- $U_{op. min.}$ Lower limit of the operative range of the coil voltage (reliable operate voltage)
- $U_{rel. min.}$ Lower limit of the operative range of the coil voltage (reliable release voltage)

Insulation Data

| | |
|--|----------------------|
| Initial dielectric strength | |
| between open contacts | 750V _{rms} |
| between contact and coil | 1050V _{rms} |
| between adjacent contacts | 750V _{rms} |
| Initial surge withstand voltage | |
| between open contacts | 1500V |
| between contact and coil | 1500V |
| between adjacent contacts | 1500V |
| Initial insulation resistance at 500 VDC | |
| | > 10 ⁹ Ω |
| Capacitance | |
| between open contacts | max. 2pF |
| between contact and coil | max. 4pF |
| between adjacent contacts | max. 2 pF |

RF Data

| | |
|---|-----------------|
| Isolation at 100MHz/900MHz | -39.0dB/-20.7dB |
| Insertion loss at 100MHz/900MHz | -0.02dB/-0.27dB |
| Voltage standing wave ratio (VSWR) at 100MHz/900MHz | 1.04/1.40 |

Other Data

Material compliance: EU RoHS/ELV, China RoHS, REACH, Halogen content refer to the Product Compliance Support Center at www.te.com/customer-support/rohssupportcenter

| | |
|--------------------------------------|----------------------------|
| Ambient temperature | -40 to +85°C |
| Category of environmental protection | IEC 61810 |
| Degree of protection, IEC 60529 | IP 67 |
| Vibration resistance (functional) | 10g, 10 to 55Hz |
| Shock resistance (functional) | IEC 60068-2-27 (half sine) |
| Shock resistance (destructive) | 10g |
| Terminal type | PCB-THT |
| Weight | max. 6g |
| Resistance to soldering heat THT | IEC 60068-2-20 |
| Ultrasonic cleaning | not recommended |
| Packaging unit | 1000 pcs. |

Terminal assignment

TOP view on component side of PCB

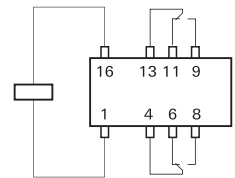

PCB layout

TOP view on component side of PCB

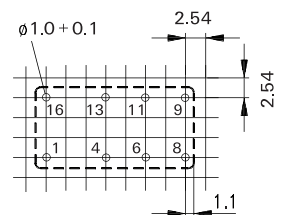

D2n Relay V23105 (Continued)

Dimensions

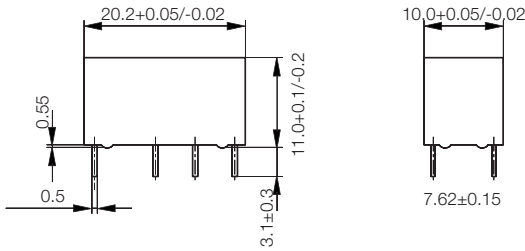

Packing

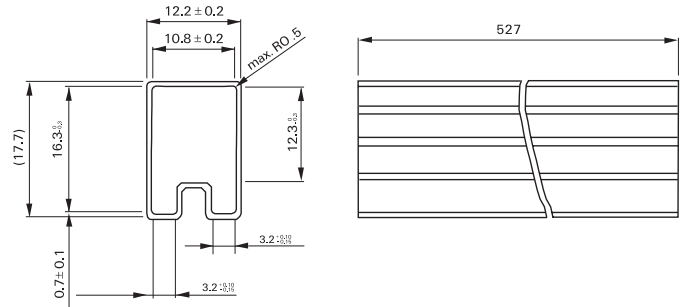

Product code structure

Typical product code **V23105-A5 001 A201**

| | | |
|-----------------|--|-------------------------|
| Type | V23105-A5 | D2n Series Signal Relay |
| Coil | Coil code: please refer to coil versions table | |
| | Coil power | |
| | 0xx 150 mW | 4xx 400 mW |
| | 3xx 300 mW | 5xx 550 mW |
| Contacts | A201 2 form C, 2 CO, AgNi+Au contacts | |

| Product Code | Version | Coil power | Coil voltage | Part number | | |
|-----------------|---|---|--------------|-------------|------|-----------|
| V23105A5001A201 | AgNi+Au contacts | 150mW | 5VDC | 8-1393792-5 | | |
| V23105A5002A201 | | | 6VDC | 8-1393792-7 | | |
| V23105A5006A201 | | | 9VDC | 9-1393792-1 | | |
| V23105A5003A201 | | | 12VDC | 8-1393792-8 | | |
| V23105A5005A201 | 200mW | 200mW | 24VDC | 9-1393792-0 | | |
| V23105A5308A201 | | | 3VDC | 1393793-5 | | |
| V23105A5301A201 | | | 5VDC | 9-1393792-3 | | |
| V23105A5302A201 | | | 6VDC | 9-1393792-5 | | |
| V23105A5306A201 | | | 9VDC | 1393793-2 | | |
| V23105A5303A201 | | | 12VDC | 9-1393792-7 | | |
| V23105A5305A201 | | | 24VDC | 9-1393792-9 | | |
| V23105A5307A201 | | | 48VDC | 1393793-3 | | |
| V23105A5401A201 | | | 400mW | 400mW | 5VDC | 1393793-6 |
| V23105A5402A201 | | | | | 6VDC | 1393793-7 |
| V23105A5406A201 | 9VDC | 1-1393793-0 | | | | |
| V23105A5403A201 | 12VDC | 1393793-8 | | | | |
| V23105A5405A201 | 24VDC | 1393793-9 | | | | |
| V23105A5407A201 | 48VDC | 1-1393793-1 | | | | |
| V23105A5501A201 | >500mW | >500mW | 5VDC | 1-1393793-6 | | |
| V23105A5502A201 | | | 6VDC | 1-1393793-8 | | |
| V23105A5506A201 | | | 9VDC | 2-1393793-3 | | |
| V23105A5503A201 | | | 12VDC | 1-1393793-9 | | |
| V23105A5505A201 | | | 24VDC | 2-1393793-1 | | |
| V23105A5507A201 | | | 48VDC | 2-1393793-4 | | |
| V23105A5475A201 | BT 47 type spec T4563C (current tested) | BT 47 type spec T4563C (current tested) | 5VDC | 1-1393793-2 | | |
| V23105A5479A201 | | | 10VDC | 3-1393794-0 | | |
| V23105A5476A201 | | | 12VDC | 1-1393793-3 | | |
| V23105A5477A201 | | | 24VDC | 1-1393793-4 | | |
| V23105A5478A201 | | | 48VDC | 1-1393793-5 | | |